

V Tundish to Mould Shrouding

Tundish to Mould Shrouding Technology

At Vesuvius, our Technical Refractory Specialists and Account Managers work closely with our customers to offer and design Tundish to Mould shrouding solutions that best suit their operational requirements (safety, quality, tundish schedule, etc).

Vesuvius offers the following technologies for Tundish to Mould Shrouding: Tundish Nozzle and Submerged Entry Shroud, Tundish Slide Gate or Tube Changer Nozzle and Shroud, and one piece Submerged Entry Nozzles.

The primary objective of tundish to mould shrouding is the controlled submerged entry and distribution of molten steel from the tundish into the mould thereby preventing reoxidation of the steel and improving quality.



Tundish Submerged Entry Nozzle (SEN)

The traditional casting practice is to use a SEN with a Tundish Stopper to control the flow of molten steel into the mould. A SEN is a one piece isostatically pressed tube that is specifically engineered for each individual customer's casting requirements. A SEN can be used for any size or shape of mould – conventional slab, medium slab, thin slab, bloom, beam-blank and billet. The SEN seat and Tundish Stopper nose are engineered to precisely control the flow of molten steel from the tundish into the mould. Specialty mixes enhance the life of the SEN and improve the steel quality of our customers. These mixes can be precisely zoned to target a specific area of the product. The Vesuvius Flow Modelling Team designs the SEN casting channel incorporating innovative bore and port geometries to optimise the flow and distribution of the molten steel in the mould.

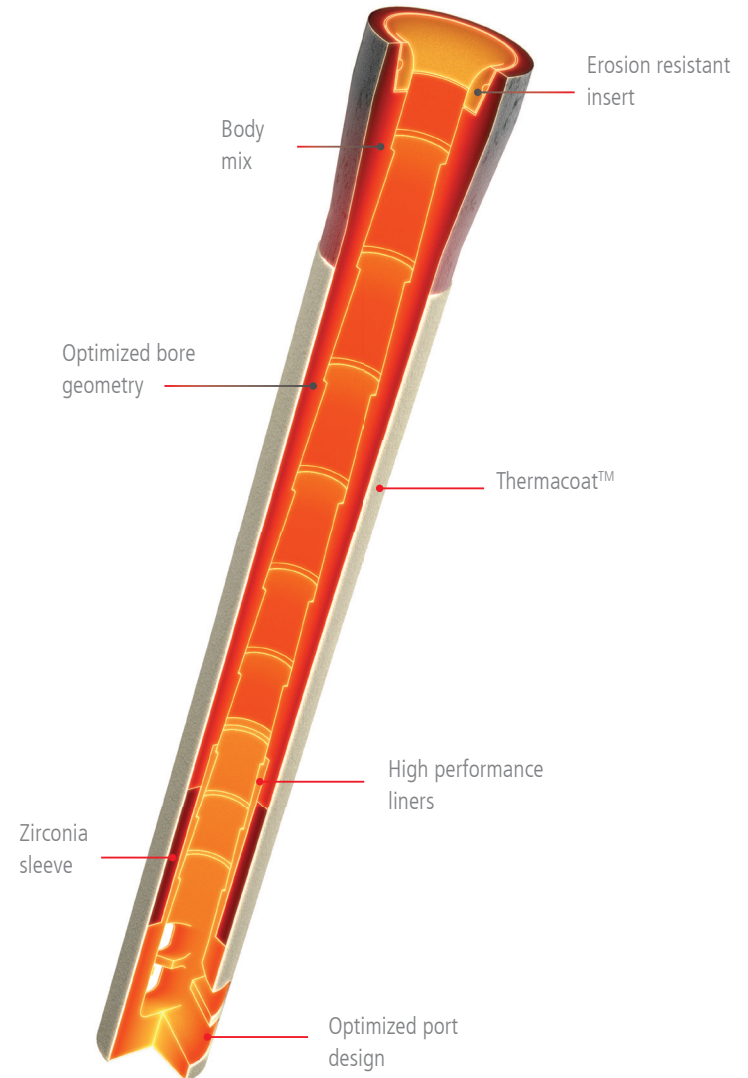

Tundish Mechanisms

Vesuvius is the world leader in Tundish Mechanisms. We offer different technologies to our customers depending on their needs. For slab and large bloom caster applications that require the shroud to be changed, Vesuvius offers a range of tube changer systems and the specific refractory components designed for each of them. A tube changer improves the safety, reliability and efficiency of our customers' operations, whilst simultaneously reducing operational costs by enabling longer casting sequences.

Precise flow control and alignment in the mould are other attributes of the Vesuvius Tube Changer products. The tube changer refractory set consists of two components: the Tundish Nozzle Plate and the Tundish Shroud Plate. Tube changers are available with stopper or slide gate control in both hydraulic and pneumatic versions.

For small bloom and billet casters, Vesuvius offers Tundish Mechanisms with slide gate control. These mechanisms insure an air tight shrouding system to improve safety and downstream quality. Slide gate control systems use three slide gate plates that precisely control the flow into a uniquely designed alumina graphite tundish shroud.

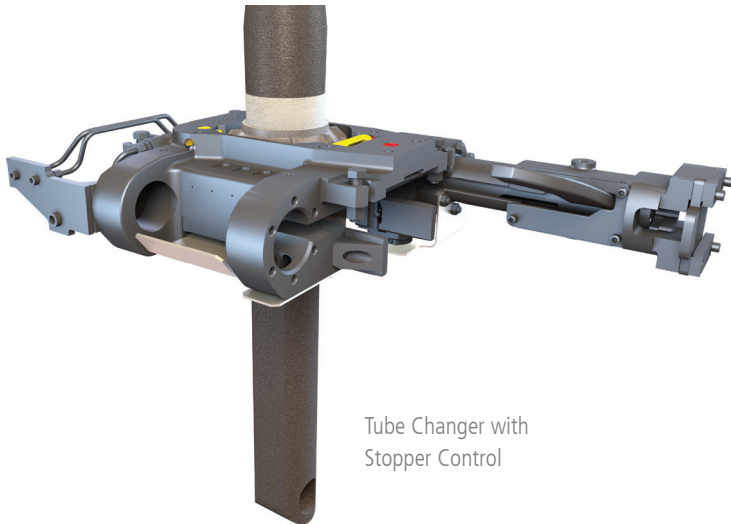

Tube Changer with
Stopper Control

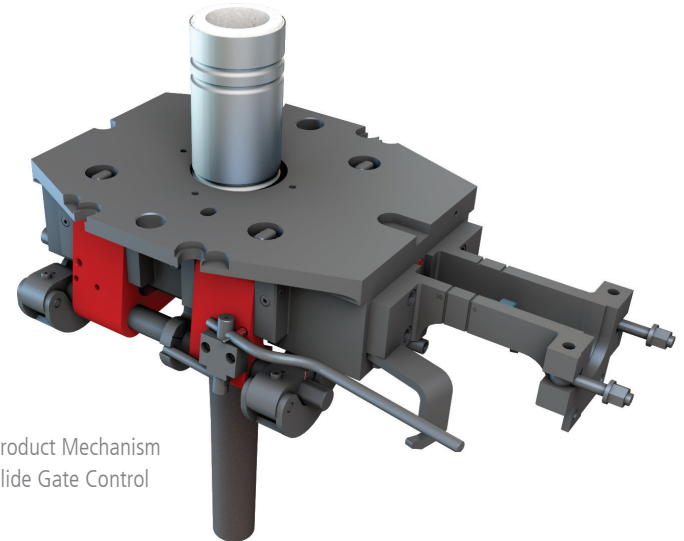

Long Product Mechanism
with Slide Gate Control

Tube Changer with Stopper Control

Monoblock Tundish Nozzle Plate (MTNP)

The MTNP is essentially the seat of the SEN in combination with a flat sealing plate to allow a safe connection with the MTSP. The MTNP will be mounted into Tundish casting channel together with the Tube Changer Mechanism. The seat of the MTNP will be engineered with the Tundish Stopper to match the required performance (throughput, steel grades, etc) of the customer.

The MTNP also incorporates argon distribution to the seat and the plate region. Argon in the seat area of the MTNP is used to keep the seating region free from alumina deposits. The argon delivery to the plate region of the MTNP is used to maintain a positive pressure between the MTNP and MTSP. This positive pressure guarantees a perfect seal between the MTNP and MTSP preventing air aspiration.

Monoblock Tundish Shroud Plate (MTSP)

The MTSP is the bottom section of the SEN in combination with a flat sealing plate to allow a safe connection to the MTNP. The MTSP is mounted and hydraulically or pneumatically fired into the Tundish casting channel via the Tube Changer Mechanism. Like the SEN, the MTSP is specifically engineered to optimize the flow between the tundish and mould as well as within the mould. The MTSP will also incorporate specialty mixes to enhance the life of the product. The plate surface of both the MTSP and MTNP incorporate abrasion resistance mixes designed to survive the effects of tube changes.

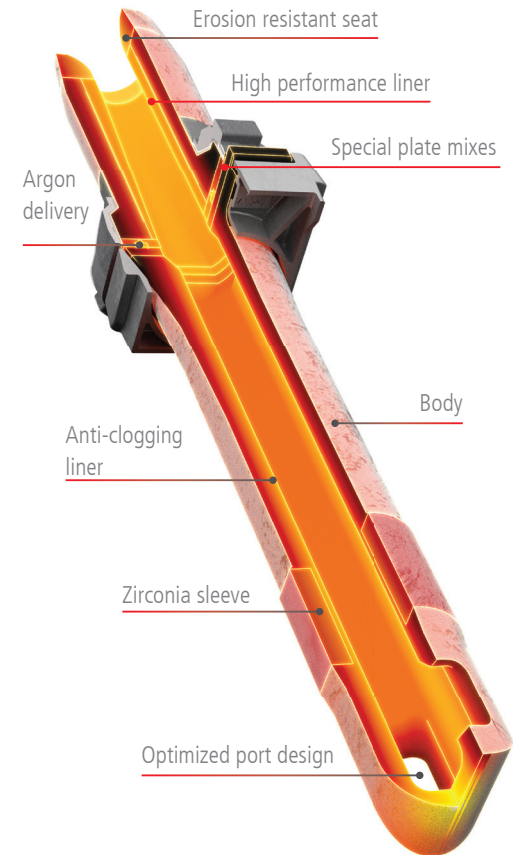

Tundish Nozzle & Submerged Entry Shroud (SES)

For Billet/Bloom and Slab applications, a Tundish Slide Gate or Tundish Nozzle and SES can replace the one piece SEN. The Tundish Nozzle and SES are designed to provide all the functions of a SEN plus the possibility to manually exchange the SES during casting, as opposed to the automatic operation performed by the Tube Changer System. The Tundish Nozzle and SES offer a simple solution to our customer's casting needs.

Tundish Nozzle

Like the SEN and MTNP, the Tundish Nozzle is engineered with the Tundish Stopper to control the steel flow into the mould. Special Mixes can be zoned in the Tundish Nozzle to optimize performance for the customer.

Submerged Entry Shroud

The SES is connected to the Tundish Nozzle or the Collector Nozzle of the Tundish Slide Gate and performs the same function as the SEN to protect the steel from re-oxidation and distribute the molten steel in the mould.

Connections

There are three main types of connections for joining the Tundish Nozzle with the SES:

- Butt Fitt connection
- Conical connection
- Spherical connection

In all three designs, Vesuvius recommends using a gasket to insure an air tight connection is established each time.

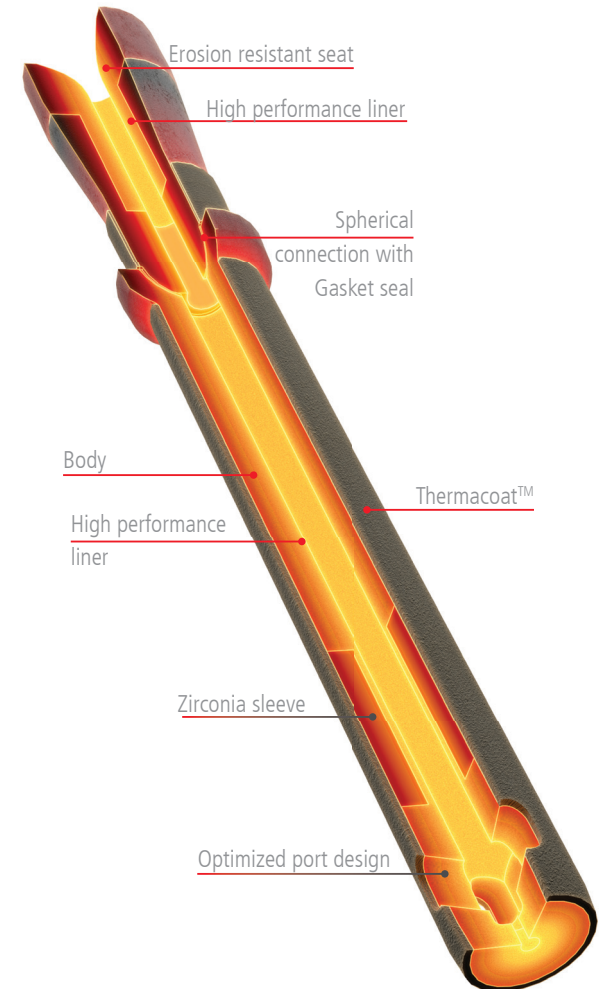

Material Selection

Vesuvius leads the industry in mix development and we offer a wide product portfolio that covers the full spectrum of casting conditions and steel chemistries. Our Product Specialists work directly with our customers to provide the proper materials for their casting needs.

Erosion Resistant Seat and Plate Area

Vesuvius offers a variety of mixes for SEN and Tundish Nozzle Seats and the MTNP/MTSP plate sections. The selection of mixes range from standard alumina graphite, magnesia and spinel mixes to state-of-the-art low carbon liners. For SEN and Tundish nozzle seats, the mixes are directly involved in the control of the molten steel and must be capable of withstanding chemical attack as well as erosion by the flow of steel. For the MTSP and MTNP, the materials must be able to withstand the abrasion that occurs during the tube change to prevent re-oxidation of the steel due to air aspiration.

Body Mixes

Vesuvius offers a variety of alumina graphite body compositions ranging from long life to cold start applications.

Slag Line Sleeves

One of the most critical regions of the Tundish to Mould shroud or nozzle is the interface between the mould powder, the steel and the refractory.

Vesuvius refractory experts work together with our mould powder team to study this interface.

Vesuvius offers a wide selection of zirconia graphite mixes specifically designed to withstand the chemical attack caused by the mould powders. These products range from cold start zirconia mixes to mixes designed to prevent Longitudinal Face Cracking (LFC's).

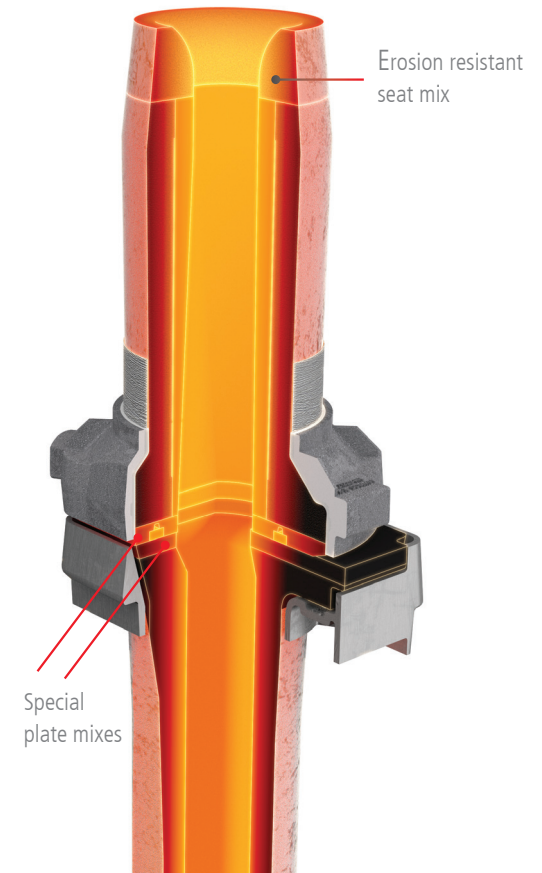

High Performance Materials for Ports and Liners

Controlling Alumina Buildup

The interior and the submerged portion of a Tundish Shroud or Nozzle can be subject to various conditions that can limit the life of the product. Among them are alumina build-up, erosion, corrosion and steel penetration. To address them Vesuvius employs a variety of materials as liners and in the area of the outlet ports.

A key factor in limiting the life of Tundish Shrouds and Tundish Nozzles is alumina clogging when casting aluminium killed steels. To combat this challenging problem, Vesuvius has the following mix technologies available:

Anti-clogging Materials:

- Body and Ports – a range of materials with different silica contents is available to produce Tundish Shrouds tailored to the customer's requirements and conditions, allowing to match the durability of the refractory to the unique tendency to clogging each customer has.
- Liners – Vesuvius has developed proprietary technology to form anti-clogging materials as liners around complicated shapes. This technology enables the deployment of low-Carbon materials that are complex to process but are the most effective against clogging.

Permeable Liner: Vesuvius offers high permeability liners used to distribute Argon into the casting channel. The Argon flow reduces alumina build-up by preventing the alumina from adhering to the refractory walls, and by forming bubbles to which the alumina particles adhere, later floating to the surface of the mould.

Reducing Erosion and Corrosion

Vesuvius offers a variety of Alumina-Graphite materials to withstand the customer's operating conditions in terms of flow conditions, chemical interaction with the steel grade cast and casting time.

These materials range from erosion/corrosion resistant materials for the submerged portion of the shroud or nozzle that are able to retain their mechanical strength and chemical and microstructural integrity even after long casting times, to special low Carbon materials to be used as liners that have high erosion resistance for the most demanding flow conditions and reduced chemical interaction with steel.

Thermally Insulating Liners

In order to enhance the thermal shock resistance of a Tundish Shroud or Nozzle, when necessary because of caster equipment limitations, beside cold-start materials Vesuvius can offer a thermally insulating liner, which not only helps preventing failure by thermal shock, but also reduces thermal loss of the steel flowing into the mould.

Eliminating Steel Penetration

For aggressive steel applications, like some stainless steels, Vesuvius offers designs with special mix formulations that resist steel penetration and allow the customer to operate with extended casting campaigns.

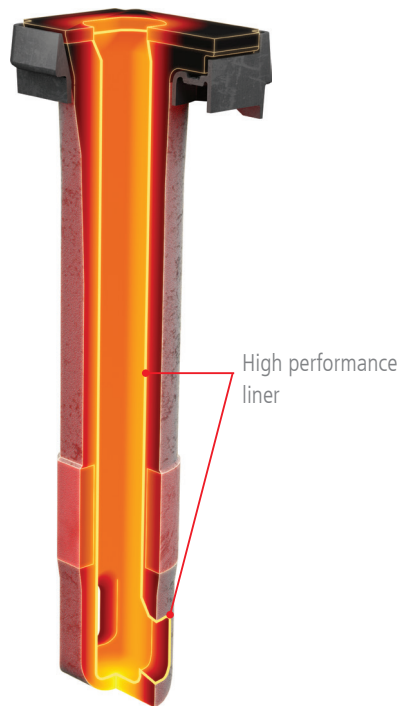

Coatings

Glaze

One of the most important components of an alumina-graphite product is the glaze, the coating that protects the refractory from oxidation. Vesuvius offers a variety of glaze compositions that cover the spectrum of pre-heat and casting conditions. For the most severe conditions Vesuvius has developed complex glaze solutions that extend the life and the working temperature range, ensuring the product is not oxidized even in the most severe preheat and casting conditions.

Thermacoat™

Another important factor to consider when designing a Tundish Shroud is thermal insulation of the outer surface. This insulation is used to retain the heat acquired during preheat. This is typically achieved by using ceramic fibers.

At Vesuvius, we developed a fiber free insulating coating, called Thermacoat™, to replace traditional ceramic fiber.

Thermacoat™ provides insulation to the alumina graphite product while eliminating the risk of exposing our customers to hazardous ceramic fibers.

Design for Flow Optimisation

Vesuvius has five flow modelling facilities around the globe strategically positioned to work with our Customers and Technical Refractory Specialists to design a unique Tundish to Mould casting solution. Our Flow Modelling Engineers use Water Modelling and Computational Flow Modelling to simulate real casting conditions. Typical problems that have been solved by our Engineers are enhanced port designs for improved flow into the mould to reduce slivers and breakouts and improved bore designs to reduce alumina build-up.



R3 Thinslab

Casting Technologies

When the first Thin Slab Caster was commissioned, Vesuvius was there to supply the first Submerged Entry Nozzle that cast the first heat, but we did not stop there. To maintain our leadership position, Vesuvius Research and Flow Modelling Engineers work closely with our customers and OEMs. This close collaboration has assisted in the development of new materials and creative designs. These new concepts have led to improved flow into the mould, improved steel quality, increased casting speeds and longer casting sequences.



Water model

i-Cast

Terraced MTSP

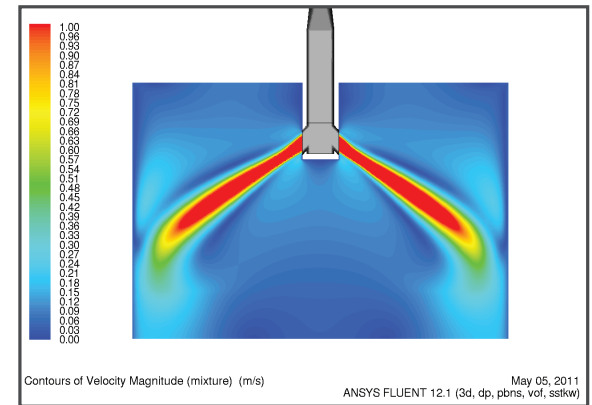

Computational

Casting into the Future

As customers strive to reduce operational costs, energy consumption and CO₂ emissions, the face of continuous casting will change. By working with the key developers of new technologies, Vesuvius will continue to satisfy the demands of the market by anticipating the needs of our customers. Our track record shows that whatever the challenge faced by our customers, from the advent of continuous casting through the development of thin slab and thin strip casting, and with an increasingly demanding range of new steel qualities, Vesuvius Flow Control has always come through with the solution. Vesuvius is dedicated to providing technical solutions that will support Continuous Casting into the future.

Terrace ports



Swirl ports

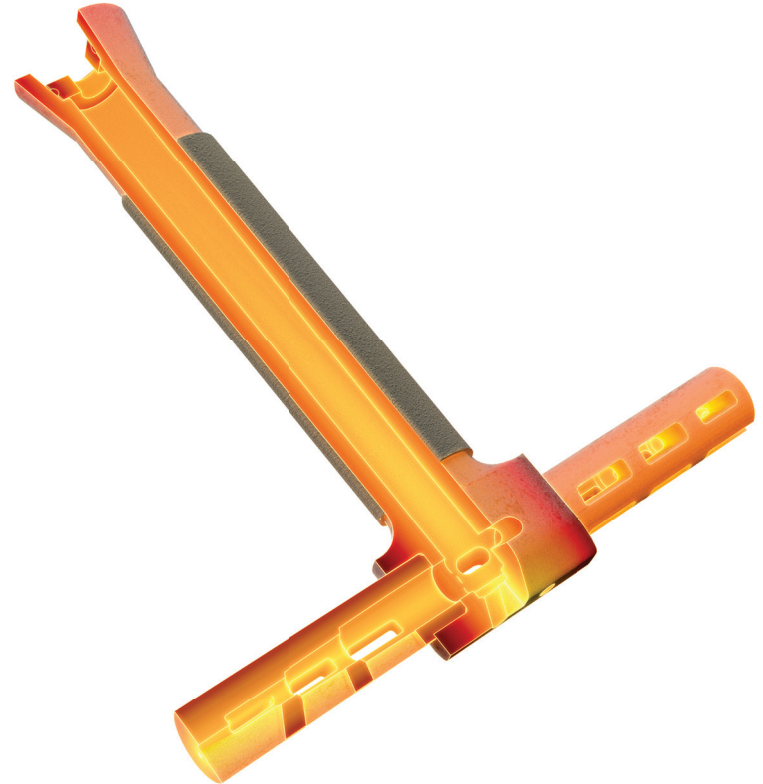
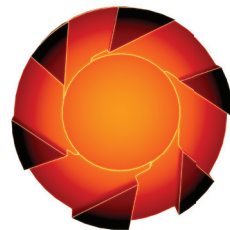
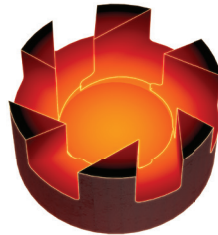



For more information on this product, please contact our local service center :

VESUVIUS GROUP, S.A.

Rue de Douvrain, 17
7011 Ghlin, Belgium
Tel: +32 65 400 810
Fax +32 65 311 474

VESUVIUS USA CORP.

250 Park west Drive
Pittsburgh, PA 15275
USA
Tel: +1 412 276 1750
Fax: +1 412 429 3448

VESUVIUS ADVANCED CERAMICS (CHINA) CO., LTD

221 Xing Ming Street
China-Singapore Suzhou Industrial Park
Suzhou 215021, JiangSu Province
P.R. of China
Tel.: +86 512 6741 2088
Fax: +86 512 6741 1700

VESUVIUS REFRATARIOS, LTDA

Av. Brazil 49.550
Distrito Industrial de Palmares
CEP 23065-480-Campo Grande
Rio de Janeiro, Brazil
Tel: +55 21 2414 0606
Fax: +55 21 2414 0648

VESUVIUS INDIA LTD

P 104, Taratolla Road
700088 Calcutta, India
Tel: +91 33 240 10 234
Fax: +91 33 240 11 235

The physical and/or chemical properties and specifications of the products set forth herein represent typical average results obtained in accordance with generally accepted standard test methods conducted under controlled conditions, and are subject to normal manufacturing variations. Vesuvius reserves the right to modify the properties and specifications at any time without prior notice. This brochure is not a warranty of any kind, either expressed or implied. Any warranty of merchantability or of fitness for a particular purpose is expressly disclaimed. Users expressly assume all risks and liabilities arising from the use of or reliance upon this information.

© copyright Vesuvius Group S.A. 2015 all rights reserved. All product names in this brochure are trademarks or registered trademarks of Vesuvius plc group of companies.